

DADEX

u-PVC

Tubewell Casing & Screen Pipes System
Product Information

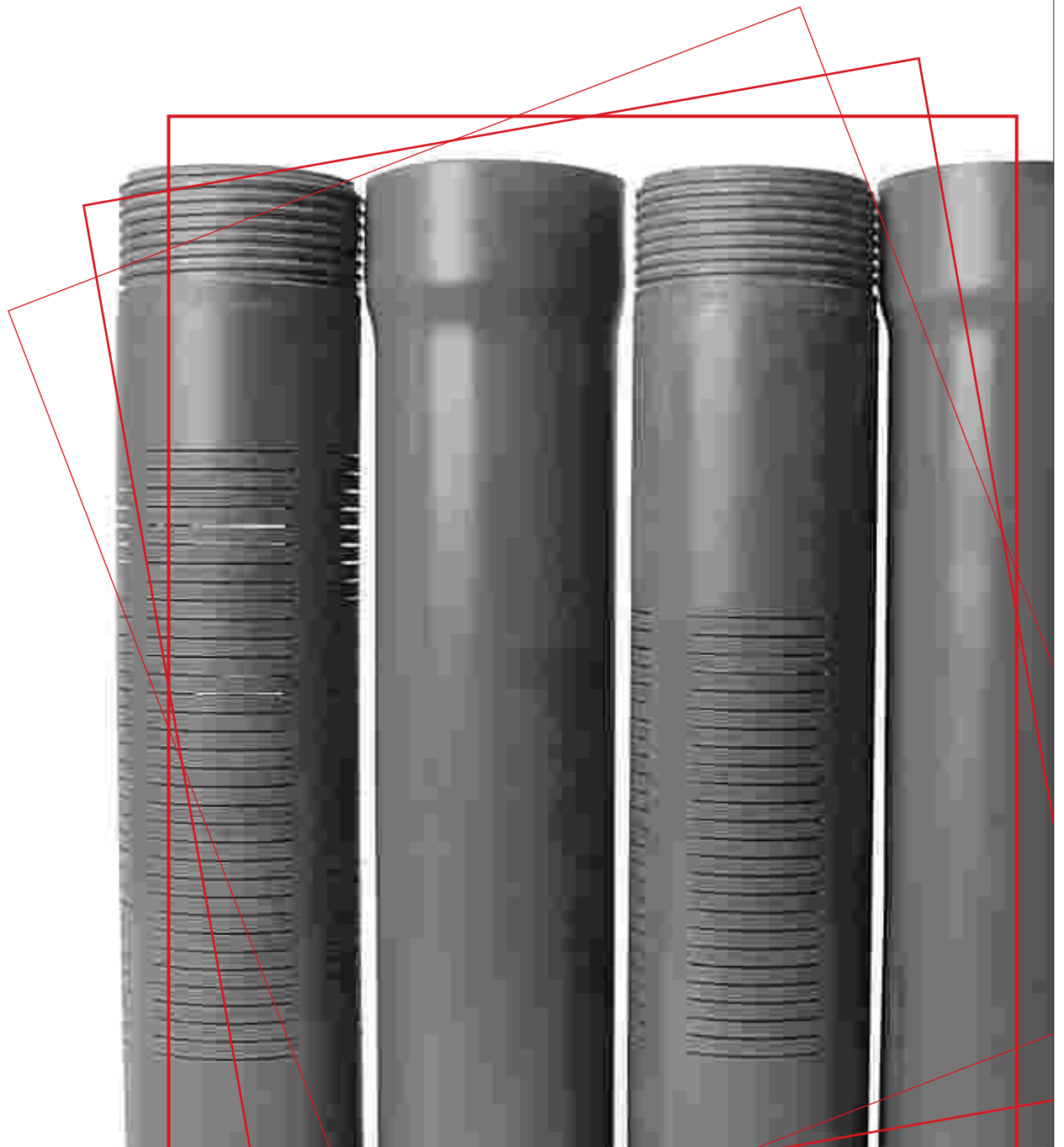

Tubewell Casing and Screen Pipes System

DADEX u-PVC CASING & SCREEN PIPES

The heart of any water well is the casing pipe and screen. Properly selected and installed, they ensure that the water well remains a perennial source of clean water. Since some years ago, the only choice was metal pipes and screens. The inherent disadvantages were corrosion of casing pipes, deterioration of screens and formation of bacteria, resulting in abandonment of wells and, even worse, contamination of the water source.

Today, modern technology has enabled us to make use of plastic pipes for this application. u-PVC casing pipes and screen pipes score tremendously over conventional metal piping because they are tough, do not corrode and last for years.

Dadex is the pioneer in introducing state-of-the-art technology for development of u-PVC casing and screen pipes that meet all requirements of customers for a durable pipe system.

Casing and screen pipes (with male and female threads) and screen pipes (with horizontal slotting) are manufactured on advanced machinery, imported from Europe and manned by highly qualified and skilled technicians.

Product Range and Specification:

- u-PVC casing pipes with male and female threaded sockets in diameters 4" & 6" (Class D), 8" & 10" (Class C & D) are available in a standard length of 4 meters.
- u-PVC screen pipes in diameters 4" & 6" (Class D), 8" & 10" (Class C & D) are available in a standard length of 4 meters.

SELECTION OF PIPES AND MATERIAL:

Basic considerations for selection of pipe include:

- Casing diameter
- Resistance to external/internal pressure.
- Design of slots

Casing Diameter:

Casing diameter depends on diameter of borehole and cost. Dadex u-PVC casing pipes can be installed to depths of normal water well construction and in borehole ranging from 4", 6", 8" & 10" in diameter. The advantages of lightweight, economy and long life give Dadex casing pipes the decisive edge over other contemporary materials used in water well construction.

Casing diameter is also dependent on the size of the submersible pump to be installed. Ideally, internal

diameter of the casing should be at least 50mm (2") greater than the outer diameter of the pump. However, economic conditions and specific applications of casing pipes may make selection of a size with lower clearance than mentioned above possible. Adoption of a telescopic design for the same purpose is also another option. Ensure that installed length of pump chamber is sufficient to accommodate the pump even when the pumping water level is at its lowest.

Resistance to External/Internal Pressure:

Maximum hydraulic loading on casing pipes occurs during installation, gravel packing, back filling and development of the water well. Hydrostatic pressure is caused by the column of drilling fluid or water present in the borehole. Rapid installation of a gravel pack or back fill increases the pressure on casing and screen pipes. Bridging and later collapse of gravel or backfill into the borehole can further subject casing pipes and screen pipes to shock loads. Poor mud control during water well development can also subject the casing to hydrostatic or differential pressure loading.

Dadex screen pipes have the capacity to withstand hydraulic pressure. It is vital that the user makes a thorough assessment of each site requirement and only then select from our range of u-PVC casing and screen pipes.

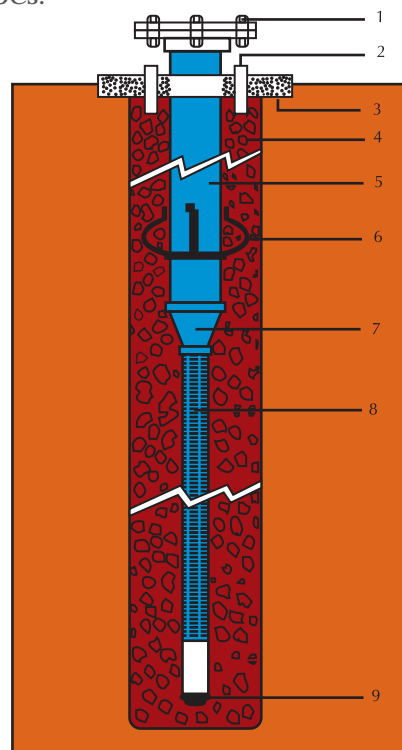

Index To The Figure

1. Bolted Capping Flange
2. Gravel Top-up Pipes
3. Platform
4. Gravel Pack
5. u-PVC Casing Pipes
6. Centering Guide
7. Reducer
8. u-PVC Screen Pipe
9. End Cap/Plug

ADVANTAGES:

Corrosion resistant: Being smooth from inside, they do not corrode and hence do not allow encrustation.

Lightweight: Easy to transport; a big advantage in areas where road conditions are not good.

Easy to handle and install: High quality threaded joints ensure easy site assembly and installation.

Non-conductive: No electro-chemical action with water thus preventing encrustation in pipes.

Economical: Far more cost effective than conventional metal piping.

INSTALLATION ACCESSORIES:

End Caps: For sealing bottom of casing and screen pipes.

Centering Guides: Centering guides are required for use on all sizes of casings and screen pipes to ensure proper positioning of the casing in the borehole and uniform gravel packing around the casing and screen pipes.

Reducers: Required in case of the need of connecting casing and screen pipes of different diameters.

Thread Protectors:

Thread protectors protect threads on socket/spigot against any damage during transportation and loading of casing and screen pipes.

WELL SCREEN SELECTION:

We manufacture u-PVC screens pipes to meet the following requirements:

- Resistance to corrosion
- High screen strength
- Design and layout of slots for maximum and smooth flow of water into the well
- Cost effective

Resistance to Corrosion:

All Dadex u-PVC screen pipes are resistant to corrosion. As u-PVC is inherently more resistant than conventional steel products to clogging and encrustation, at a fraction of the cost. Dadex u-PVC screen pipes are generally unaffected by substances encountered in wells; hence no deterioration in slots takes place. The raw material used for manufacturing fully complies with drinking water regulations and does not affect the quality of water.

High Screen Strength:

Dadex screen pipes are designed to withstand:

- a) Tensile loading
- b) Lateral pressure

Screen Design/Slot Layout:

Screens are available in slot widths ranging from 0.20 mm to 3 mm cut transverse to pipe axis. This arrangement of pipes gives the screen optimum hydraulic efficiency. Flow is facilitated avoiding convergence into the screen thereby preventing unnecessary entrance losses.

Dadex offers a comprehensive range of different diameters, wall thicknesses and slot widths to match the need for an economical and ideal well design.

The percentage of open areas available for each slot width and nominal diameter of pipe can be provided.

DIMENSIONS AND PATTERN OF PERFORATION

Perforation width, w (mm)					0.2 ^{+0.06}	0.3 ^{+0.08}	0.5 ^{+0.1}	0.75 ^{+0.2}	1.0 ^{+0.2}	1.5 ^{+0.2}	2.0 ^{+0.2}	3.0 ^{+0.3}
Class	Nominal diameter (inches)	Internal diameter, ID (mm)	n min	Σa Ø 5% (mm)	f, as a percentage							
D	4	100.9	5	206	3.5	5.1	5.9	8.7	9.1	9.4	11.8	-
D	6	148.7	5	278	-	-	5.4	8.0	8.3	8.6	10.8	13.3
C	8	201.8	6	390	-	-	-	8.2	8.6	8.9	11.1	13.7
D	8	196.2	6	390	-	-	-	8.5	8.8	9.1	11.5	14.1
C	10	251.6	6	450	-	-	-	7.6	7.9	8.2	10.3	12.7
D	10	244.8	6	450	-	-	-	7.8	8.2	8.4	10.6	13.0
Rib width, b (mm)					4	5.5	6.8	9.5	11.0			

Note:

- f Approximate total effective perforation area
- Σa Summation of slot lengths over the internal circumference of the cross section
- n Minimum number of perforations in one plane
- b Distance between two slots or rib width

PHYSICAL PROPERTIES OF u-PVC MATERIAL

Properties	Unit	Value
Specific Gravity	-	1.42-1.46
Tensile Strength	Mpa	45 - 60
Vicat Softening Temperature	°C	85

Tubewell Casing and Screen Pipes System

INSTALLATION PROCEDURE:

- Arrange the pipe assembly on the ground
- Fix the centering guides on the pipes once in every 15 meters (minimum), just below the neck of the socket, with the open end of the centering guides facing upwards while lowering.
- Always use a plain casing pipe (sand trap) for the first pipe to be lowered, with a conical end cap (Bull-nose) blanking the spigot end of the pipe. Fill this pipe with water or drilling fluid before lowering into the well.
- Wash the reamed borehole thoroughly with fresh drilling fluid (Bentonite Solution) for 40-45 minutes from the bottom, keeping the specific gravity of the drilling fluid to below 1.4.
- This will prevent heavy sedimentation at the bottom of the borehole and also easy lowering of the assembly.
- To obtain better results, ensure that the reamed borehole is at least 15 to 20cms more than the outside diameter of the casing pipe.
- The sand trap is the lowest pipe in a tubewell and is the first to be selected. Fit this pipe with an end plug (cap) and centering guide.
- Lower the sand trap into the borehole and hold with a split clamp with the socketed end facing upward.
- The next pipe, which is either a screen pipe or a plain pipe (depending on lithology of well) is fitted to the sand trap by screwing them together.
- Jointing of pipes can be done either by strap wrench or with manila rope. Never use a chain

wrench. Clean the threads to remove mud or burrs using wire brush. Soap solution may be used to lubricate the joints. Avoid grease or waste oil.

- Fit the socketed end of the next pipe (which can be a screen/plain casing) with the fitting cap.
- Connect the lifting cap securely with the wire rope of the drilling frame.
- Use winch of drilling machine to lift the threaded pipe string.
- This pipe string is jointed to the pipe already lowered into the borehole.
- Centre the assembled pipe string and permit it to descend into the borehole by releasing the split clamp, Fill the pipe with water or mud solution to equalize pressure.
- Repeat the operation till all the casings and screens are lowered according to the lithology of the well. The time needed to make each joint is less than 5 minutes.
- Lowering time can be reduced by jointing the casings and screens on the ground to make additional lengths. Do this correctly as per lithology of well to avoid wrong placement of screens in the bore well.

Do not set the lowered pipe assembly at the bottom of the borehole. Ensure at least 10 feet of free bore below the sand trap. This helps the lowered casing and screen pipes to remain hanging and achieve a vertical installation.

- Centering guides should always be fixed at a minimum interval of 1.5 meters to ensure uniform gravel packing around the casing and screen pipes.

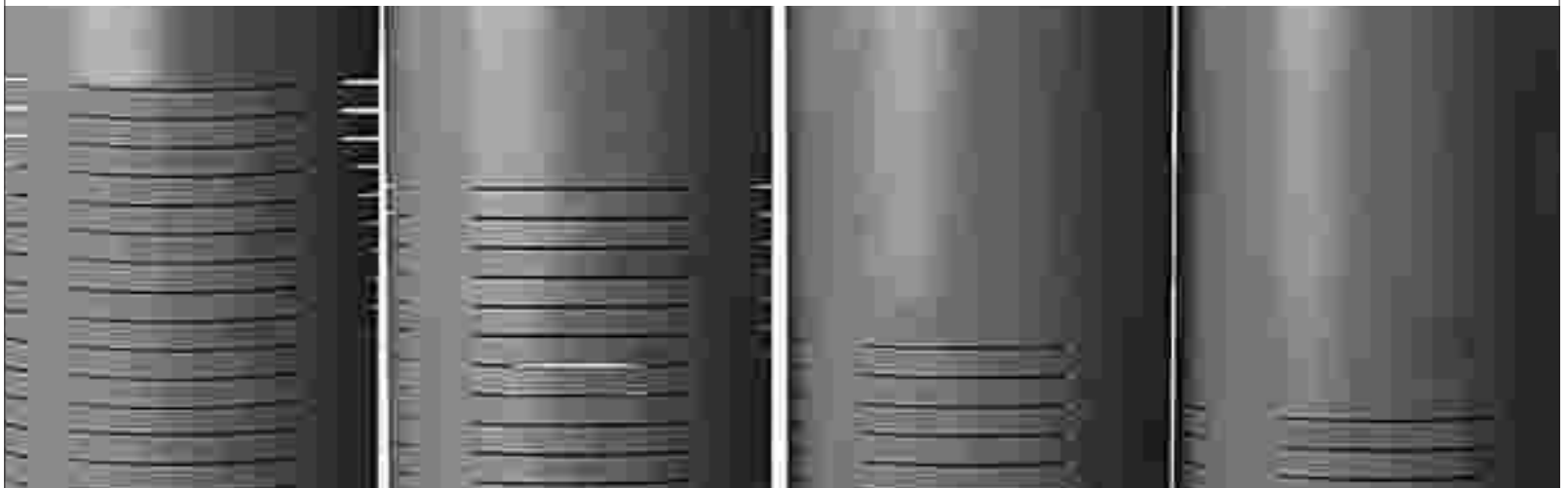

GRAVEL PACKING BY THE BACKWASH METHOD:

Gravel packing is the most important operation in successfully completing a bore. Therefore, take utmost care to ensure uniform gravel packing around casing and screen pipes without bridging the annular space.

For best results wash and grade the gravel before pouring into the annular space. The backwash method of packing gives the best results.

PRECAUTIONS:

- Do not store casing and screen pipes in direct sunlight for long periods of time. As far as possible, store in the shade. Stack neatly on flat smooth surface or on wooden platform, preferably to just 1 meter in height.
- Avoid sagging at any point of storage to prevent pipe distortion.
- The screen pipe is the heart of any water well, thus special care must be taken during transportation, handling and should be stored separately without any superimposed load.
- Casing and screen pipes should be examined minutely for any signs of damage before installation. Do not use damaged casing or screen pipes.
- Always transport and store pipes and screens with thread protectors in place. Damaged threads can result in failure during installation.
- Always use centering guides in the casing string.
- Ensure that the borehole is clear to the proposed depth of installation and free of obstructions before starting installation of casing pipe.
- Maintain steady speed during installation of the casing string. Jerky actions damage screens or joint partings. Also, avoid sudden braking during lowering.
- Do not push, drive or rotate casing pipe against any obstruction within the borehole to prevent damage to the screen.
- Avoid pouring large quantities of gravel or backfill

material at high speeds since this could lead to unnecessary loading on the screen or result in bridging.

- All joints should be tightened firmly before installation. Strap wrenches are normally used.
- During well development and testing, avoid excessive surging.
- Use extra caution when using compressed air for well development. Replacement of fluid within the casing pipe with fresh water could lead to creation of differential pressure between the drilling mud in the borehole and the water in the casing, resulting in damage to the casing or screen.
- Select and place grout material carefully.



Dadex Eternit Limited

Dadex House, 34-A/1, Block 6,
P.E.C.H.S., Shahrah-e-Faisal,
P.O.Box 20040,
Karachi 75400 - Pakistan

UAN: (021) 111 000 789, Fax: (021) 4537076, 4315716, Email: info@dadex.com

For more information log on to www.dadex.com or contact a Dadex office near you:

- **HYDERABAD**

Tel: (0223) 880613 Fax: (0223) 880623
Email: hyderabad@dadex.com.pk

- **ISLAMABAD**

UAN: (051) 111 000 789, 4440428 Fax: (051) 4440496
Email: islamabad@dadex.com.pk

- **LAHORE**

UAN: (042) 111 000 789, 5760735-36, 5712169 Fax: (042) 5760734
Email: lahore@dadex.com.pk

- **MULTAN**

Tel: (061) 545259 Fax: (061) 545259
Email: multan@dadex.com.pk

- **FAISALABAD**

Tel: (041) 8861981 Fax: (041) 8787944
Email: faisalabad@dadex.com.pk

- **PESHAWAR**

Tel: (091) 2212214 Fax: (091) 2212214
Email: peshawar@dadex.com.pk

- **QUETTA**

Tel: (081) 2446701
Email: quetta@dadex.com.pk

- **SUKKUR**

Tel: (071) 5616349
Email: sukkur@dadex.com.pk

Note: All information contained in this literature is given in good faith. The user should, however, check that the product is suitable for the application for which it shall be used. Please ensure compliance with all health and safety requirements. Whilst continuing its program of continuous development, Dadex reserves the right to modify or extend any published information without any prior notification. No responsibility can be accepted for any error, omissions or incorrect assumptions.